

RoofDek D100

Colorcoat Steel 220 N/mm²

(not including S280 Interior Liner)

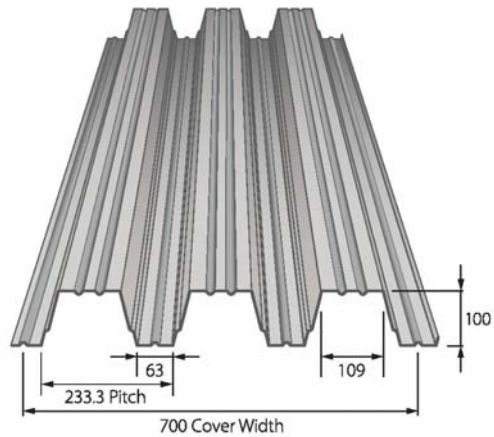

Ultimate Section Properties to Eurocode3

| Nominal Thickness mm | Design Thickness mm | Weight kg/m ² | Broad flange in compression | | Narrow flange in compression | | 100 mm Bearing on steel beam | | Shear Capacity kN/m |
|-------------------------|------------------------|-----------------------------|-----------------------------|---|------------------------------|---|------------------------------|---------------------|------------------------|
| | | | Moment Capacity kNm/m | Moment of Inertia cm ⁴ /m | Moment Capacity kNm/m | Moment of Inertia cm ⁴ /m | Transverse Resistance | Internal Rw kN/m | |
| 0.68 | 0.64 | 9.64 | 6.70 | 163.08 | 6.34 | 163.08 | 21.10 | 4.92 | 41.37 |

Safe Imposed (positive) Loads (kN/m²)

Imposed load - deflection limit span / 200

| Span Condition | Thickness mm | SPAN (metres) | | | | | | | | | | | | | | | |
|----------------|-----------------|---------------|------|------|------|------|------|------|------|------|------|------|------|------|------|------|------|
| | | 3.00 | 3.20 | 3.40 | 3.60 | 3.80 | 4.00 | 4.20 | 4.40 | 4.60 | 4.80 | 5.00 | 5.20 | 5.40 | 5.60 | 5.80 | 6.00 |
| Single | 0.68 | 2.12 | 1.99 | 1.87 | 1.76 | 1.66 | 1.58 | 1.50 | 1.43 | 1.26 | 1.09 | 0.96 | - | - | - | - | - |
| Double | 0.68 | 2.28 | 2.07 | 1.88 | 1.72 | 1.57 | 1.45 | 1.33 | 1.23 | 1.15 | 1.07 | 0.99 | 0.93 | - | - | - | - |
| Multi | 0.68 | 2.37 | 2.22 | 2.08 | 1.96 | 1.86 | 1.75 | 1.61 | 1.50 | 1.39 | 1.30 | 1.21 | 1.13 | 1.06 | 1.00 | 0.94 | - |

Safe Wind Suction (negative) Loads (kN/m²)

Wind suction load - deflection limit span / 90

| Span Condition | Thickness mm | SPAN (metres) | | | | | | | | | | | | | | | |
|----------------|-----------------|---------------|------|------|------|------|------|------|------|------|------|------|------|------|------|------|------|
| | | 3.00 | 3.20 | 3.40 | 3.60 | 3.80 | 4.00 | 4.20 | 4.40 | 4.60 | 4.80 | 5.00 | 5.20 | 5.40 | 5.60 | 5.80 | 6.00 |
| Single | 0.68 | 3.82 | 3.37 | 2.99 | 2.67 | 2.41 | 2.18 | 1.98 | 1.81 | 1.66 | 1.53 | 1.42 | - | - | - | - | - |
| Double | 0.68 | 4.03 | 3.55 | 3.15 | 2.82 | 2.54 | 2.30 | 2.09 | 1.91 | 1.75 | 1.61 | 1.49 | 1.38 | - | - | - | - |
| Multi | 0.68 | 5.02 | 4.42 | 3.92 | 3.51 | 3.15 | 2.85 | 2.59 | 2.37 | 2.17 | 2.00 | 1.85 | 1.71 | 1.59 | 1.49 | 1.39 | - |

NOTES Black figures are stress limited, the load shown is the ultimate load divided by 1.5.

Blue figures are deflection limited.

Red figures indicate that deck length exceeds 12m the maximum advisable. Consider extended end laps

Jan-12

T: +44 (0)845 30 88 330

E: roofdek@tatasteel.com

Calculations are to Eurocode, however additional checks such as fixings are required

A construction line load 2 kN/m has been allowed for.

Deck self weight has been allowed for, so does not have to be included in applied loads