

RoofDek D100

Steel 280 N/mm²

Interior Liner and Galvanised finish

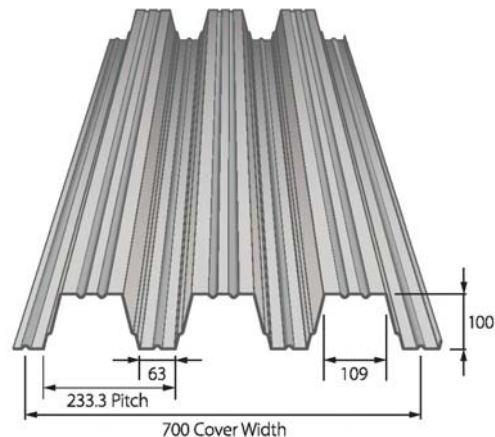

Ultimate Section Properties to Eurocode3

Nominal Thickness mm	Design Thickness mm	Weight kg/m ²	Broad flange in compression		Narrow flange in compression		100 mm Bearing on steel beam		Shear Capacity kN/m
			Moment Capacity kNm/m	Moment of Inertia cm ⁴ /m	Moment Capacity kNm/m	Moment of Inertia cm ⁴ /m	Transverse Resistance	Internal Rw kN/m	
0.70	0.66	9.64	8.08	169.49	8.16	169.49	25.77	6.04	50.19
0.90	0.86	12.41	11.93	220.74	11.01	220.74	43.75	10.61	82.37
1.20	1.16	16.57	16.98	297.51	14.94	297.51	77.76	19.63	144.85

Safe Imposed (positive) Loads (kN/m²)

Imposed load - deflection limit span / 200

Span Condition	Thickness mm	SPAN (metres)															
		4.00	4.20	4.40	4.60	4.80	5.00	5.20	5.40	5.60	5.80	6.00	6.20	6.40	6.60	6.80	7.00
Single	0.70	1.95	1.75	1.51	1.31	1.14	1.00	-	-	-	-	-	-	-	-	-	-
	0.90	2.66	2.28	1.97	1.71	1.49	1.30	1.14	1.01	-	-	-	-	-	-	-	-
	1.20	3.59	3.08	2.65	2.30	2.01	1.76	1.54	1.36	1.20	1.07	0.95	-	-	-	-	-
Double	0.70	1.83	1.69	1.57	1.46	1.36	1.27	1.19	1.11	1.04	0.98	0.93	-	-	-	-	-
	0.90	2.73	2.52	2.33	2.16	2.01	1.87	1.75	1.64	1.53	1.44	1.36	1.28	1.20	1.14	1.08	1.02
	1.20	4.10	3.77	3.47	3.21	2.98	2.77	2.58	2.41	2.26	2.12	1.99	1.87	1.76	1.66	1.57	1.49
Multi	0.70	2.17	2.04	1.90	1.77	1.65	1.54	1.44	1.35	1.27	1.20	1.13	1.07	1.01	0.96	0.91	-
	0.90	3.31	3.05	2.83	2.63	2.44	2.28	2.13	2.00	1.88	1.76	1.66	1.57	1.48	1.37	1.24	1.13
	1.20	4.98	4.59	4.24	3.92	3.64	3.39	3.17	2.96	2.77	2.60	2.45	2.26	2.04	1.85	1.68	1.52

Safe Wind Suction (negative) Loads (kN/m²)

Wind suction load - deflection limit span / 90

Span Condition	Thickness mm	SPAN (metres)															
		4.00	4.20	4.40	4.60	4.80	5.00	5.20	5.40	5.60	5.80	6.00	6.20	6.40	6.60	6.80	7.00
Single	0.70	2.78	2.53	2.31	2.12	1.95	1.80	-	-	-	-	-	-	-	-	-	-
	0.90	3.75	3.41	3.11	2.86	2.63	2.43	2.25	2.09	-	-	-	-	-	-	-	-
	1.20	5.09	4.62	4.22	3.87	3.57	3.30	3.05	2.84	2.65	2.48	2.32	-	-	-	-	-
Double	0.70	2.76	2.50	2.29	2.10	1.93	1.79	1.66	1.54	1.44	1.34	1.26	-	-	-	-	-
	0.90	4.06	3.69	3.37	3.09	2.84	2.63	2.43	2.26	2.11	1.97	1.85	1.74	1.63	1.54	1.46	1.38
	1.20	5.77	5.24	4.79	4.39	4.04	3.73	3.46	3.21	3.00	2.80	2.62	2.46	2.32	2.19	2.07	1.96
Multi	0.70	3.43	3.12	2.84	2.61	2.40	2.22	2.05	1.91	1.78	1.66	1.56	1.46	1.38	1.30	1.23	-
	0.90	5.05	4.59	4.19	3.84	3.53	3.26	3.02	2.81	2.62	2.44	2.29	2.15	2.02	1.91	1.80	1.70
	1.20	7.19	6.53	5.96	5.46	5.02	4.64	4.30	3.99	3.72	3.47	3.25	3.05	2.87	2.71	2.56	2.42

NOTES Black figures are stress limited, the load shown is the ultimate load divided by 1.5.

Blue figures are deflection limited.

Red figures indicate that deck length exceeds 12m the maximum advisable. Consider extended end laps

Calculations are to Eurocode, however additional checks such as fixings are required

A construction line load 2 kN/m has been allowed for.

Deck self weight has been allowed for, so does not have to be included in applied loads